

10/2008  
APXE-TL  
N°1

## APXE-TL

Rep.	Nom du produit	Beschreibung	Description	Designacion	Наименование	Code
1	Chassis APXETL tube 150x100 nu/	Rahmen/	Main frame/	Cajonera/		APX00014
2	Vis T.H. 20x 90 8.8 brut/	Schraube 20x90/	Screw 20x90/	Tornillo 20x90/	Болт Т.Н.20x 90 8.8 /	VIS20013
3	Palier½ gros rond inférieur/alésage Ø 95 (bague bronz	Lager/	Bearing/	Cojinete/	Корлус лодшилников S III	PAL00012
4	Bague ½ bronze Ø95/90 lg 60/autoporteur	1/2 Buchse/	1/2 Bushing/	1/2 Casquillo/	Кольцо S бронзовое III95/90	BAG09500
5	Rondelle grower WL Ø20/	Scheibe WL Ø20/	Washer WL Ø20/	Arandela WL Ø20/	Шайба grower WL III20/	RON02000
6	Ecrou nylstop M20 Zn/DIN 985	Mutter M20/	Nut M20/	Tuerca M20/	Гайка nylstop M20 Zn DIN 9	ECR20003
7	Bouchon tube 150x100x8/plastique	Stopfen/	Plug/	Tapòn/		BOU10005
8	Axe Ø 45x305 M33x200 (sous tête)	Achse/	Axle/	Eje/		AXE45001
9	Rondelle plate 34x80x10/	Scheibe 34x80x10/	Washer 34x80x10/	Arandela 34x80x10/		RON03400
10	Ecrou H. M33x200 percé M8/	Mutter M33x200/	Nut M33x200/	Tuerca M33x200/	Гайка Н. М33x200 просверл	ECR33002
11	Ecrou H. M 8 Zn/	Mutter M8/	Nut M8/	Tuerca M8/	Гайка Н. М 8 Zn/	ECR08002
12	Vis T.H.C. 8x20 8.8 brut b.poi/	Schraube M8x20/	Screw M8x20/	Tornillo M8x20/	Болт Т.Н.С. 8x20 8.8/	VIS08015
13	Catadioptr orange Ø54 adhésif/	Rückstrahler/	Reflector/	Reflector/		SIG00103
14	Graisseur M 8 droit/	Schmiernippel/	Grease nipple/	Engrasador/	Масленка М 8 лрямая/	GRA08001

10/2008  
APXE-TL  
N°2

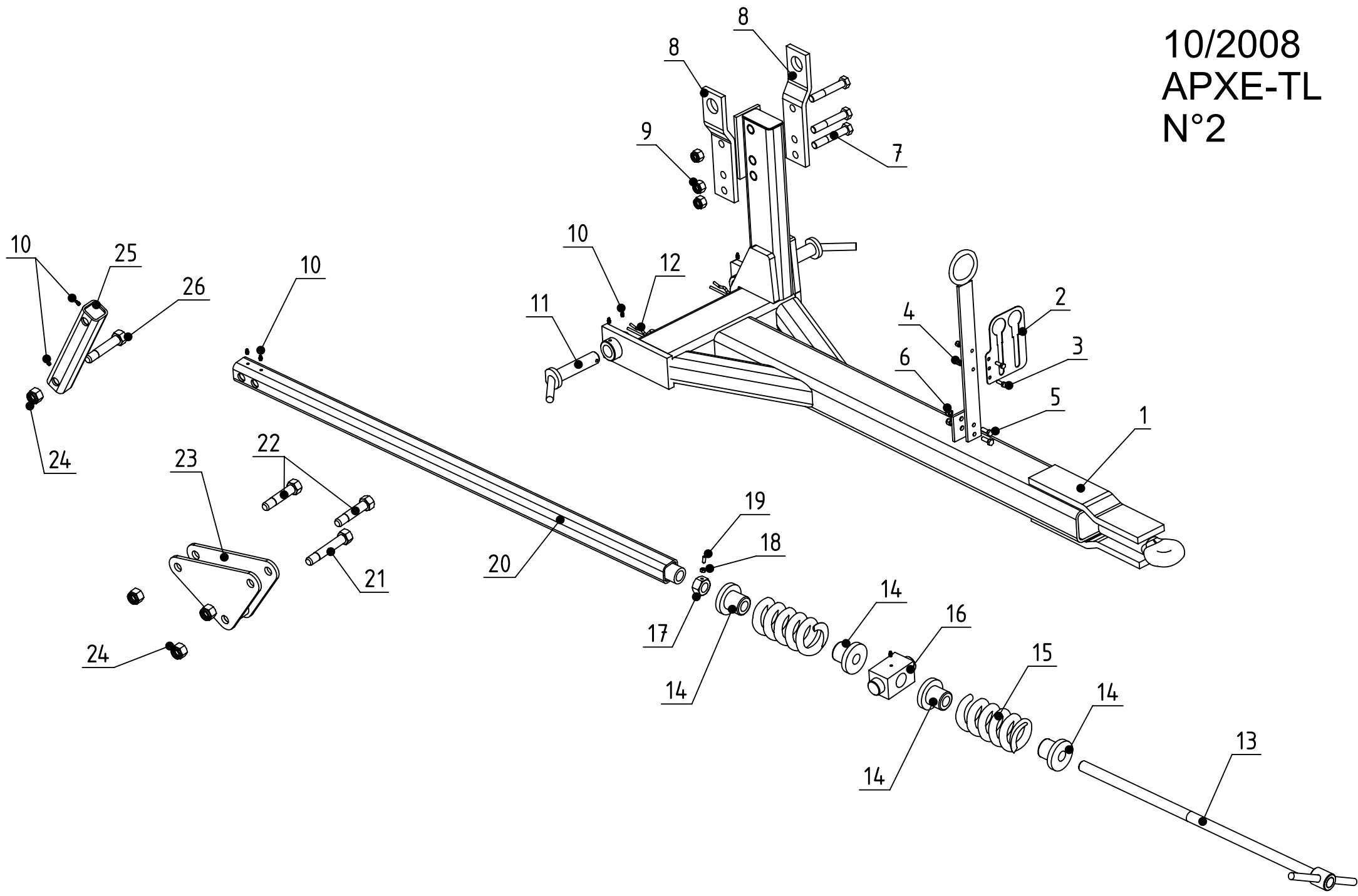

APXE-TL

Rep.	Nom du produit	Beschreibung	Description	Designacion	Наименование	Code
1	Flèche nue APXETL/	Zugdeichsel/	Drawbar/	Lanza de enganche/		FLE00008
2	Plat support de flexibles/(5 flexibles) PLAN N°0198 /200	Platte/	Plate/	Placa/	Олорная лластина шлангов	FLE00057
3	Vis T.H. 8x 25 8,8 Zn/filetage total	Schraube/	Screw/	Tornillo/	Болт Т.Н.8x25 8.8 zn/	VIS08028
4	Ecrou nylstop M 8 Zn/	Mutter M8/	Nut M8/	Tuerca M8/	Гайка М 8 Zn/	ECR08001
5	Vis T.H. 10x 30 8.8 Zn/entierement fileté DIN 933	Schraube 10x30/	Screw 10x30/	Tornillo 10x30/	Болт Т.Н.10x 30 8.8 Zn/	VIS10009
6	Ecrou nylstop M10 Zn/DIN 985 0871	Mutter M10/	Nut M10/	Tuerca M10/	Гайка nylstop M10 Zn/	ECR10002
7	Vis T.H. 20x120 8,8 Zn/	Schraube 20x120/	Screw 20x120/	Tornillo 20x120/	Винт Т.Н. 20x120 8,8 Zn/	VIS20033
8	Plat déporté (trou Ø45)/	Flacher Teil/	Track/	Lano/	Пластина смещенная (отв.	FLE00005
9	Ecrou nylstop M20 Zn/DIN 985	Mutter M20/	Nut M20/	Tuerca M20/	Гайка nylstop M20 Zn DIN 9	ECR20003
10	Graisneur M 8 droit/	Schmiernippel/	Grease nipple/	Engrasador/	Масленка М 8 лрямая/	GRA08001
11	Broche d'attelage Ø35x160/	Zugspindel Ø35x160/	Hitch pin Ø35x160/	Passador de la horquilla Ø3		BRO03500
12	Goupille beta Ø6/	Stift beta Ø6/	Pin beta Ø6/	Pasador beta Ø6/	Штифт beta Ш6/	GOU06000
13	Vis de télescopique Ø30/lg 930	Schraube/	Screw/	Tornillo/		VIS30001
14	Rondelle fonte T3 BRUTE/	Scheibe/	Washer/	Arandela/		RON03002
15	Ressort compr.Ø104 lg215 fil/Ø22	Feder Ø104x22x215/	Spring Ø104x22x215/	Muelle Ø104x22x215/		RES22000
16	Carré d'articulation lg 140/pour vis Ø30	Gelenkev/	Articulation/	Articulaciones/		FLE00006
17	Ecrou H. M30 brut percé M8/	Mutter M30 nicht standard/	Nut M30 special/	Tuerca M30 especial/	Гайка Н. М30 /	ECR30003
18	Ecrou H. M 8 Zn/	Mutter M8/	Nut M8/	Tuerca M8/	Гайка Н. М 8 Zn/	ECR08002
19	Vis T.H.C. 8x20 8.8 brut b.poi/	Schraube M8x20/	Screw M8x20/	Tornillo M8x20/	Болт Т.Н.С. 8x20 8.8/	VIS08015
20	Tube de liaison lg 1610 vis/M30-triangle APXETL	Tube/	Tube/	Tubo/		APX00015
21	Boulon T.H.25x145 M24 (acier)/(sous tête)	Bolzen/	Bolt/	Bùlon/	Болт Т.Н.25x145 M24 /	BLS24009
22	Boulon T.H.25x115 M24 (acier)/(sous tête)	Bolzen/	Bolt/	Bùlon/	Болт Т.Н.25x115 M24/	BLS24010
23	Triangle de liaison APXETL/	Gelenkverbindung/	Connection/	Articulacion/		APX00016
24	Ecrou nylstop M24 Zn/	Mutter M24/	Nut M24/	Tuerca M24/	Гайка nylstop M24 Zn/	ECR24003
25	Tube de liaison lg 350/triangle-gros rond APXETL	Tube/	Tube/	Tubo/		APX00017
26	Boulon T.H.25x125 M24 (acier)/(sous tête)	Achse Ø25x125 - M24/	Axle Ø25x125 - M24/	Eje Ø25x125 - M24/	Болт Т.Н.25x125 M24 (стал	BLS24014

10/2008  
APXE-TL  
N°3

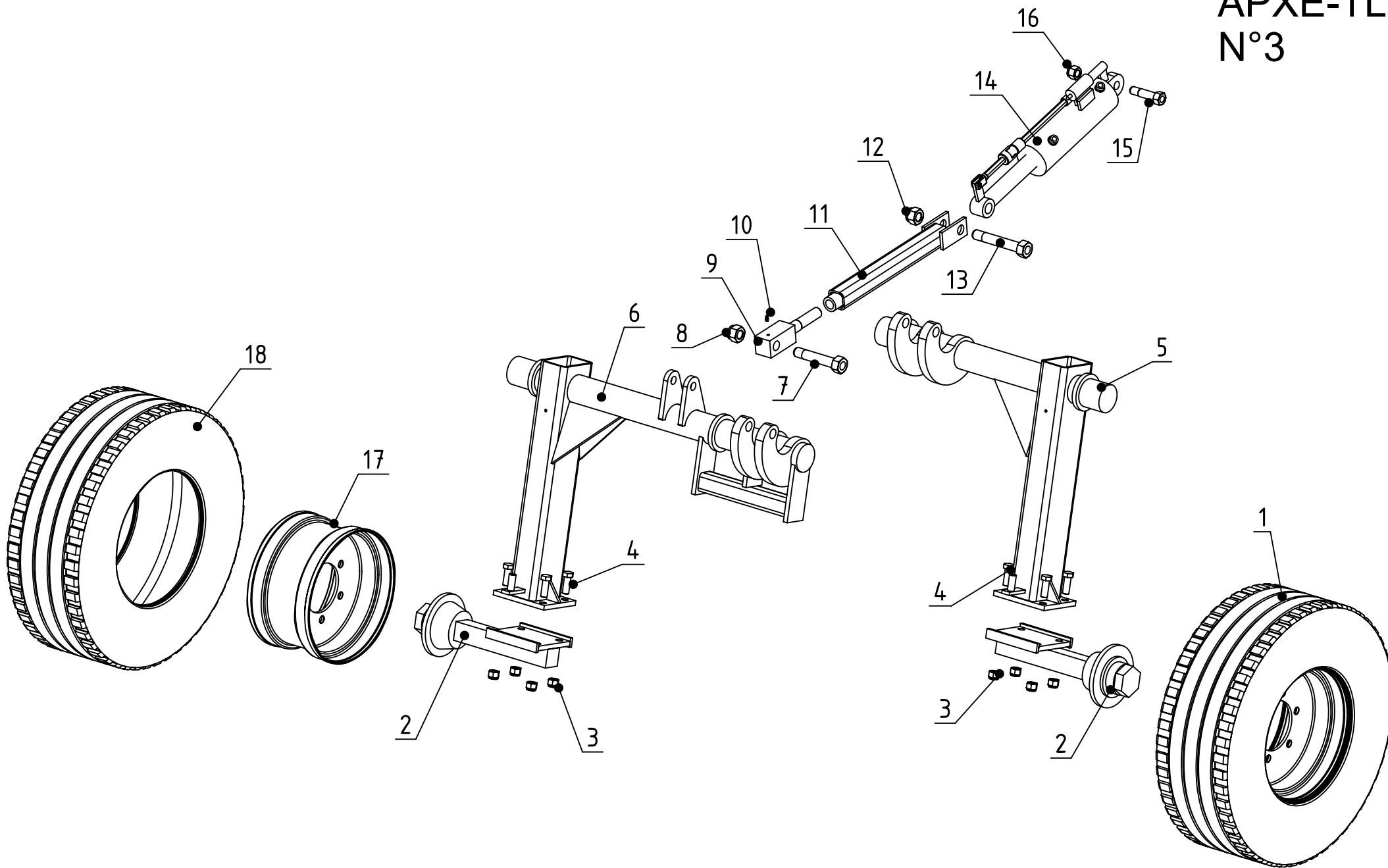

APXE-TL

Rep.	Nom du produit	Beschreibung	Description	Designacion	Наименование	Code
1	Roue 10/75x15,3/6trous 10 plys/	Rad 10x15/	Wheel 10x15/	Rueda 10x15/	Колесо 10x15/6 отв. 10 шли	RPN01001
2	Essieu ½ complet c70-6 axes/voie 440 frein 300x60	Radachse/	Wheel axle/	Eje/		ESS07031
3	Ecrou nylstop M20 Zn/DIN 985	Mutter M20/	Nut M20/	Tuerca M20/	Гайка nylstop M20 Zn DIN 9	ECR20003
4	Vis T.H. 20x 55 8.8 brut/filetage total	Schraube 20x55/	Screw 20x55/	Tornillo 20x55/	Болт Т.Н.20x 55 8.8 лолнор	VIS20003
5	Gros rond APXETL AV (bague/bronze Ø95/90) bielles	Tragplatterad/	Wheel bracket/	Soporte de rueda/		GRD00012
6	Gros rond APXETL AR (bague/bronze Ø95/90) bielles	Tragplatterad/	Wheel bracket/	Soporte de rueda/		GRD00007
7	Boulon T.H.30x160 M30 (acier)/(sous tête)	Bolzen/	Bolt/	Perno/	Болт Т.Н.30x160 M30 (стал	BLS30001
8	Ecrou nylstop M30 Zn/	Mutter M30/	Nut M30/	Tuerca M30/	Гайка nylstop M30 Zn/	ECR30002
9	Carré de réglage M33x200 trou/Ø30	Verstellungswelle M33x200/	End block link bar M33x200/	Barra del acoplamiento/	Регулировочная пластина/	APX00011
10	Graisseur M 8 droit/	Schmiernippel/	Grease nipple/	Engrasador/	Масленка М 8 лрямая/	GRA08001
11	Tube de renvoi M33x200 lg 52/0 trou Ø 30,5	Tube/	Tube/	Tubo/		APX00056
12	Ecrou nylstop M30 Zn/	Mutter M30/	Nut M30/	Tuerca M30/	Гайка nylstop M30 Zn/	ECR30002
13	Boulon T.H.30x190 M30 (acier)/(sous tête)	Bolzen/	Bolt/	Bùlon/	Болт Т.Н.30x190 M30 (стал	BLS30002
14	Vérin DE: 50x100 C: 200 EF:480/douillé Ø30,5 prise dé Zylinder/		Cylinder/	Cilindro hidraulico/		VER05004
14	Pochette de joints pour vérin/DE: 50x100 (après 1985)	Dichtungen/	Seal kit/	Juntas/	Комллект лрокладок для ги	PJT05001
15	Boulon T.H.25x100 M24 (acier)/(sous tête)	Bolzen/	Bolt/	Perno/	Болт Т.Н.25x100 M24 /	BLS24005
16	Ecrou nylstop M24 Zn/	Mutter M24/	Nut M24/	Tuerca M24/	Гайка nylstop M24 Zn/	ECR24003
17	Jante 10x15/6 trous/	Radfelge 10x15/	Wheel rim 10x15/	Llanta de rueda 10x15/	Диск колеса 10x15/6 отв./	JAN01001
18	Pneu 10x15 10 plys/	Reifen 10x15/	Tyre 10x15/	Neumatico 10x15/	Шина 10x15 /	PNE01001

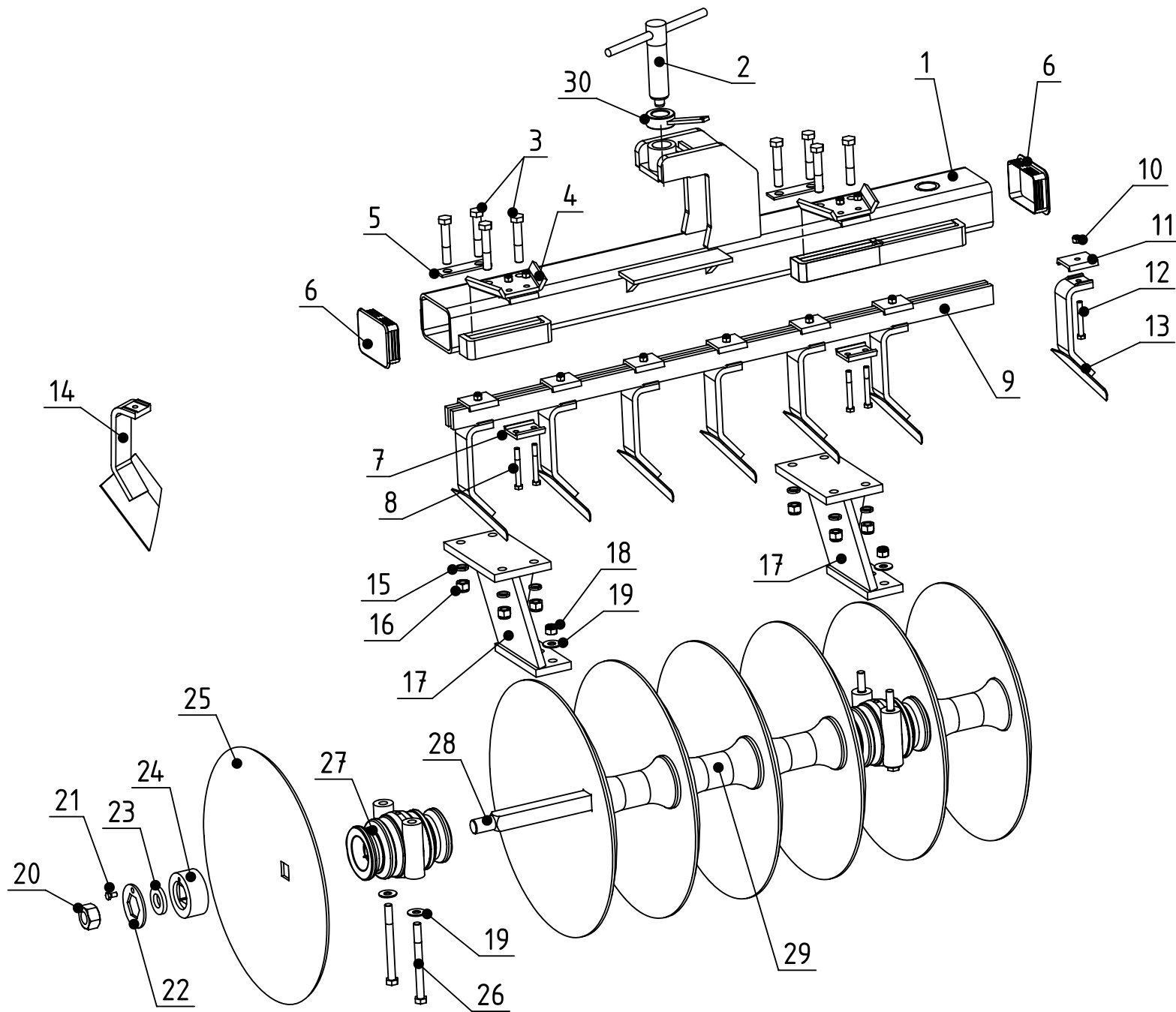

10/2008  
APXE-TL  
N°4



APXE-TL

Rep.	Nom du produit	Beschreibung	Description	Designacion	Наименование	Code
1	Traverse nue (nous consulter)/	Tube/	Tube/	Tube/	Траверса /	TRX00000
2	Vis TL M48/	Schraube/	Screw/	Tornillo/	Болт TL M48/	VIS48000
3	Vis T.H. 20x110 8,8 Zn/	Schraube 20x110/	Screw 20x110/	Tornillo 20x110/	Винт Т.Н.20x110 8,8 Zn/	VIS20032
4	Plat support de barre de/raclette	Halter/	Bracket/	Soporte/	Олорная лластина бруса чис	BAT00006
5	Plaque à 2 trous support de/palier	Platte/	Plate/	Placa/	Пластина с 2 отв. олоры ко	BAT00007
6	Bouchon tube 160x120x8/plastique	Stopfen/	Plug/	Tapòn/		BOU10006
7	Chape à 2 trous/pour barre 50x15	Gabel/	Fork/	Horquilla/	Скоба с 2 отв. для бруса 50x	BAT00005
8	Vis T.H. 12x100 8.8 brut/	Schraube/	Screw/	Tornillo/	Болт Т.Н.12x 100 8.8 /	VIS12023
9	Barre de raclette (nous/consulter)	Balken/	Bar/	Barra/	Брус чистика/	BAR00000
10	Ecrou nylstop M12 Zn/DIN 985	Mutter M12/	Nut M12/	Tuerca M12/	Гайка nylstop M12 Zn DIN 9	ECR12002
11	Chape à 1 trou/pour barre 50x15	Gabel/	Fork/	Horquilla/	Штырь Ш 30x145 /	BAT00004
12	Vis T.H. 12x 90 8.8 brut/	Schraube 12x90/	Screw 12x90/	Tornillo 12x90/	Болт Т.Н.12x 90 8.8 /	VIS12022
13	Raclette AV GA et AR DR disque/Ø 610 pour support	Abstreifer/	Scraper/	Paleta/		DEC00106
13	Raclette AV GA et AR DR disque/Ø 660 sup. mécanos	Kratzer/	Scraper/	Paleta/	Скребок/	DEC00116
14	Raclette AV DR et AR GA disque/Ø 610 pour support	Abstreifer/	Scraper/	Raedera/	Чистик/	DEC00105
14	Raclette AV DR et AR GA disque/Ø 660 sup. mécanos	Abstreifer/	Scraper/	Raedera/	Скребок/	DEC00115
15	Rondelle grower WL Ø20/	Scheibe WL Ø20/	Washer WL Ø20/	Arandela WL Ø20/	Шайба grower WL Ш20/	RON02000
16	Ecrou nylstop M20 Zn/DIN 985	Mutter M20/	Nut M20/	Tuerca M20/	Гайка nylstop M20 Zn DIN 9	ECR20003
17	Support mécano-soudé ht 310/pour palier carré de 40	Halter/	Bracket/	Soporte/	Олора/	SUP10000
18	Ecrou nylstop M18 Zn/	Mutter M18/	Nut M18/	Tuerca M18/	Гайка nylstop M18 Zn/	ECR18002
19	Rondelle plate 18x35x3/	Scheibe 18x35x3/	Washer 18x35x3/	Arandela 18x35x3/		RON01801
20	Ecrou H. M36 brut pas 2 (arbre/carré de 40)	Mutter M36/	Nut M36/	Tuerca M36/	Гайка Н. М36 /	ECR36000
21	Vis T.H. 10x 20 8.8 Zn/filetage total	Schraube 10x20/	Screw 10x20/	Tornillo 10x20/	Болт Т.Н.10x 20 8.8 Zn лол	VIS10006
22	Rondelle trou hexagonal pour é/crou M36	Scheibe/	Washer/	Arandela/	Шайба/	RON00000
23	Rondelle plate 36,5x70x10/(rondelle kit arret train c40	Scheibe/	Washer/	Arandela/		RON03600
24	Rondelle acier c42 MC 714/percée M10	Scheibe/	Washer/	Arandela/	Плоская шайба/	RON04001
25	Disque (nous consulter)/	Scheiben/	Disc/	Disco/	Диск (лроконсультироватьс	DSQ00000

APXE-TL

Rep.	Nom du produit	Beschreibung	Description	Designacion	Наименование	Code
26	Vis T.H. 18x200 8.8 brut/	Schraube 18x200/	Screw 18x200/	Tornillo 18x200/	Винт/	VIS18009
27	Palier écart.230 c42 AP 230/complet	Lager/	Bearing/	Cojinete/	Подшипник в сборе/	PAL40000
28	Arbre carré (nous consulter)/	Sheiben welle/	Disc shaft/	Arbol de disco/	Квадратный вал/	CAR00000
29	Entretoise ec230 c42 C702R/usinée	Distanzring/	Spacer/	Arandela distanciadora/	Промежуточная втулка /	ENT23401
30	Ecrou vis de TL M48/	Mutter M48/	Nut M48/	Tuerca M48/	Гайка болта TL M48/	ECR48001

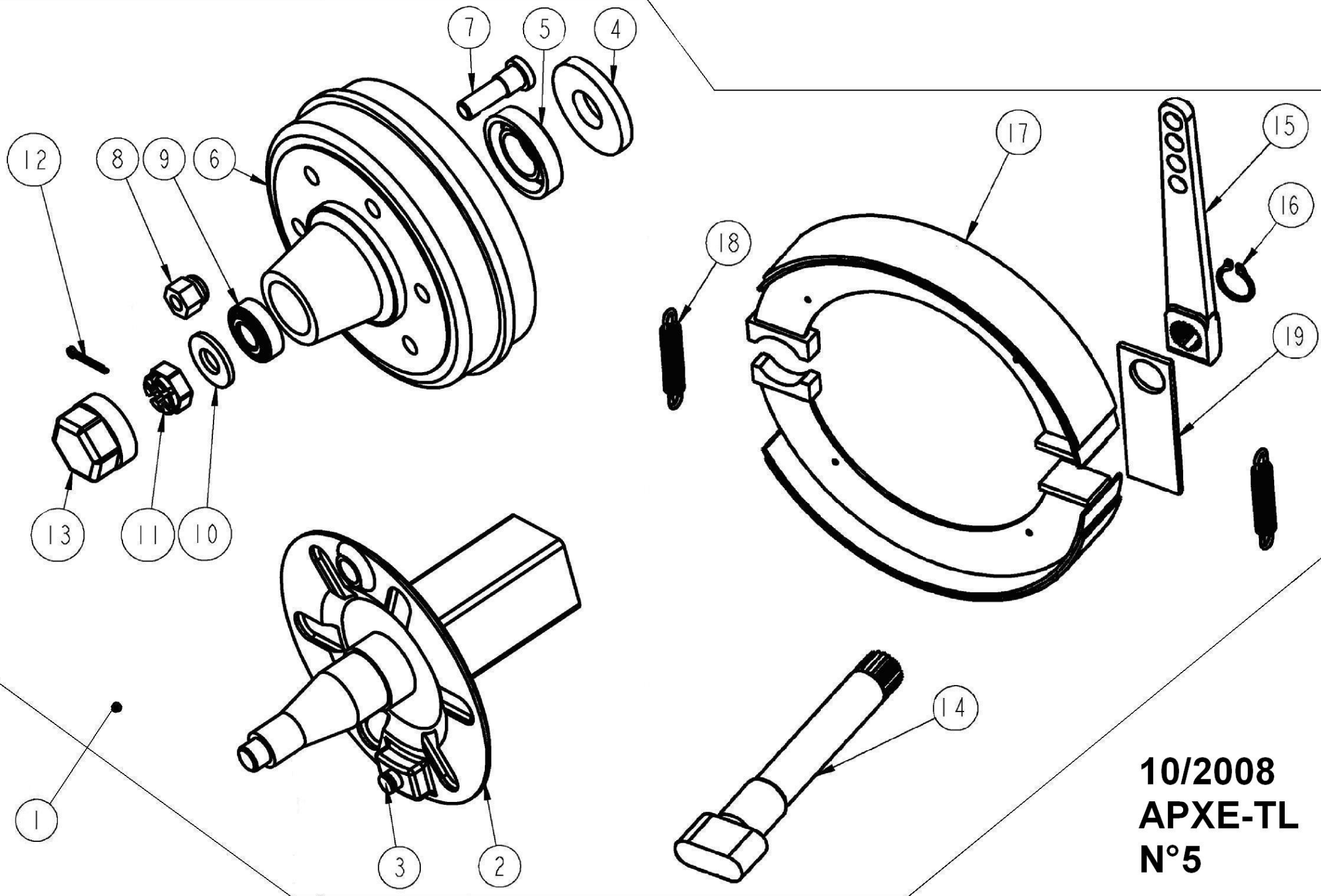

10/2008  
APXE-TL  
N°5

## APXE-TL

Rep.	Nom du produit	Beschreibung	Description	Designacion	Наименование	Code
1	Essieu ½ c70-6 axes voie 440//1 frein 300x60 lg came	Radachse/	Wheel axle/	Eje/		ESS07006
2	Flasque équipé (axe+bague)/(essieu 606MF1 300x60C	Kurbelwange/	Crankthrow/	Flanco/		ESS56103
2	Flasque de frein Ø65/	Kurbelwange/	Crankthrow/	Flanco/		ESS56104
3	Axe de frein 300x60C/	Bremsachse/	brake axle/	Eje de freno/		ESS58027
4	Rondelle de protection/100 x 55 x1,2	Scheibe/	Washer/	Aronдела/	Предохранительная шайба/	ESS56001
5	Roulement rouleau conique/100/55 réf.30211	Lager/	Bearing/	Cujinete/	Подшипник /	RLT30211
6	Moyeu monobloc 310 H/	Nabe/	Hub/	Cubo/		ESS56102
7	Goujon M18x150 lg54/39/	Gewindebolzen/	Stud/	Esparrago roscado/	Шлилька M18x150 дл.54/39	ESS56003
8	Ecrou de goujon M18x150/24 plat	Mutter/	Nut/	Tuerca/	Гайка шлильки M18x150 24	ESS56004
9	Roulement rouleau conique/80/40 réf.30208	Lager/	Bearing/	Cujinete/	Конический подшипник 80/	RLT30208
10	Rondelle plate 31x52x4/	Scheibe/	Washer/	Arandela/	Плоская шайба 31x52x4/	RON03101
11	Ecrou créneaux HK M30x200/	Mutter M30x200/	Nut M30x200/	Tuerca M30x200/	Корончатая гайка НК М30х	ECR30004
12	Goupille fendue 5 x 50 Zn/(DIN94 5x36Zn)	Stift 5x50/	Pin 5x50/	Pasador 5x50/	Разводной шплинт 5x 50 Zn	GOU05001
13	Bouchon de roue fileté Ø 81,5x/1,5	Stopfen/	Plug/	Tapòn/		ESS56101
14	Came de frein 300x 60C (/longueur sous tête à préciser	Bremsnocken/	Brake cam/	Leva del freno/		ESS56059
15	Biellette 4 trous Ø24,5 (frein/300x60C)	Schubstange/	Link/	Bieleta/		ESS56060
16	Circlips extérieur Ø 24/	Seegering/	Circlip/	Anillo/		CIR02400
17	Mâchoire de frein 300x60C/(demi machoire)	Gabel/	Yoke/	Horquilla/		ESS56061
18	Ressort de rappel frein/300x60C	Feder/	Spring/	Muelle/		ESS56062
19	Support de came de frein/300x60C lg 82	Trag/	Support/	Soporte/		ESS56105
19	Support de came de frein/300x60C lg 77	Trag/	Support/	Soporte/		ESS56106
19	Support de came de frein 300x/60C lg 87 (essieu carré	Trag/	Support/	Soporte/		ESS57102
19	Support de came de frein 300x/60C lg 92 (essieu carré	Trag/	Support/	Soporte/		ESS58128

10/2008  
APXE-TL  
N°6

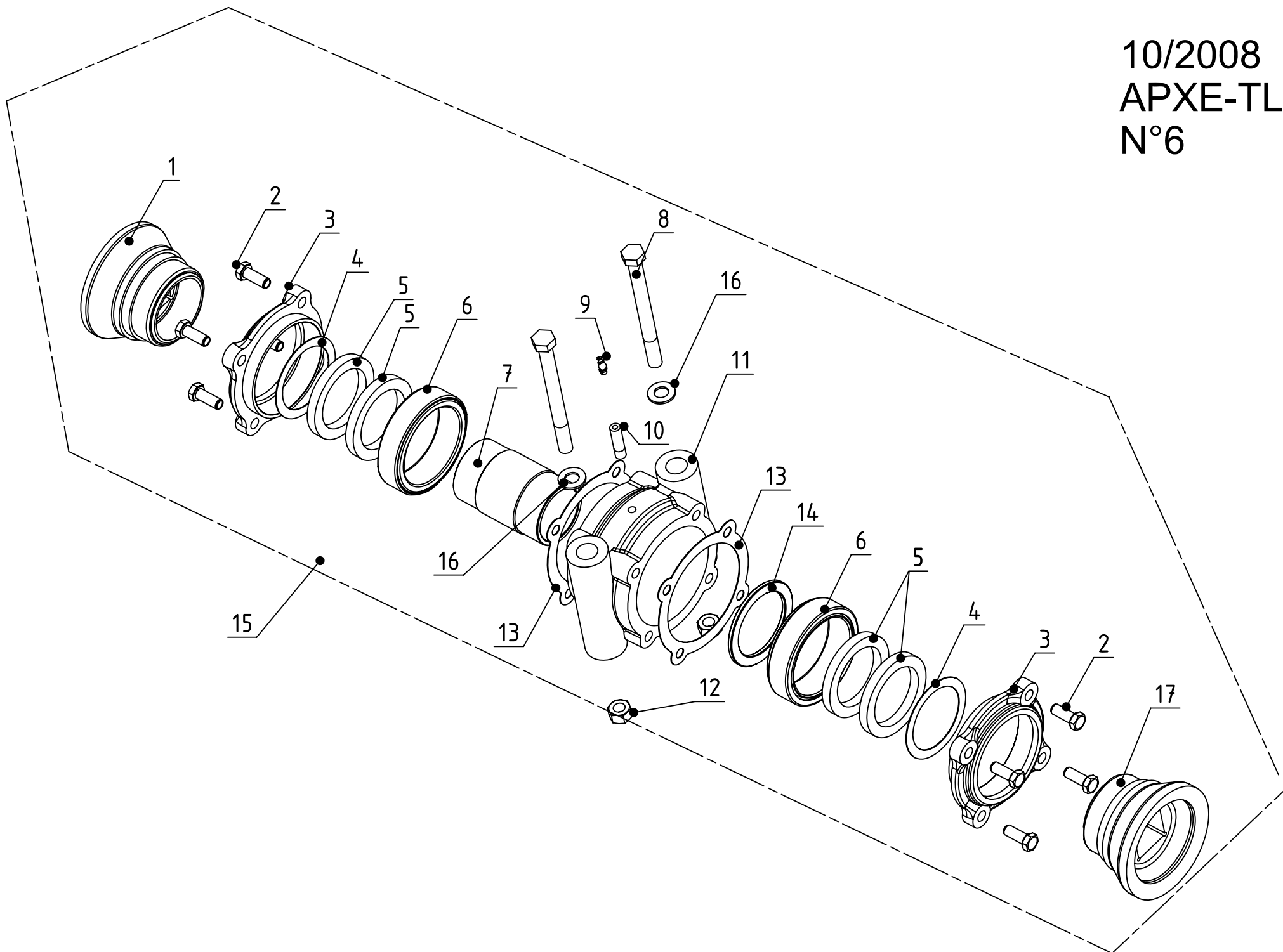

## APXE-TL

Rep.	Nom du produit	Beschreibung	Description	Designacion	Наименование	Code
1	Embout ec230 c42 creux MC616C/	Endstück/	End piece/	Pieza terminal/	Наконечник/	EMB23646
2	Vis T.H. 10x 35 6.8 brut/	Schraube/	Screw/	Tornillo/	Винт Т.Н.10x 35 6.8/	VIS10018
3	Couvercle MC 617 usiné/	Deckel/	Cover/	Tapa/	Крышка/	COU00006
4	Rondelle plate 90x115x1,2/acier (MC86)	Deckel/	Cover/	Tapa/	Плоская шайба/	RON09000
5	Joint à lèvres Ø 90x115x13 (MC6/68)	Dichtung/	Tight joint/	Junta/	Прокладка/	JOI09000
6	Roulement rouleau conique/125/70 réf.30214	Lager/	Bearing/	Cujinete/	Подшипник /	RLT30214
7	Douille MC 621/	Büchse/	Bush/	Casquillo/	Втулка/	BAG00001
8	Vis T.H. 18x200 8.8 brut/	Schraube 18x200/	Screw 18x200/	Tornillo 18x200/	Винт/	VIS18009
9	Graisseur M 8 coudé 45°	Schmiernippel/	Grease nipple/	Engrasador/	Масленка М 8 угол 45°/	GRA08000
10	Allonge de graisseur M8/	Verlängerung/	Extension/	Extensión/	Удлинитель масленки М8/	GRA08002
11	Corps palier: CVB 700 usiné/	Körper/	Casing/	Cuerpo/	Корпус подшипника/	COR00004
12	Ecrou nylstop M18 Zn/	Mutter M18/	Nut M18/	Tuerca M18/	Гайка nylstop M18 Zn/	ECR18002
13	Joint papier Ø125 pour palier/carré de 40 (MC87)	Dichtung/	Tight joint/	Junta/	Прокладка/	JOI17000
14	Bague Ø 71x 90 lg 11 (MC88)/	Büchse/	Bushing/	Casquillo/	Втулка/	BAG07101
15	Palier écart.230 c42 AP 230/complet	Lager/	Bearing/	Cojinete/	Подшипник в сборе/	PAL40000
16	Rondelle plate 19x36x3/	Scheibe/	Washer/	Arandela/	Плоская шайба/	RON01900
17	Embout ec230 c42 bombé MC616B/	Endstück/	End piece/	Pieza terminal/	Наконечник/	EMB23641

10/2008  
APXE-TL  
N°7

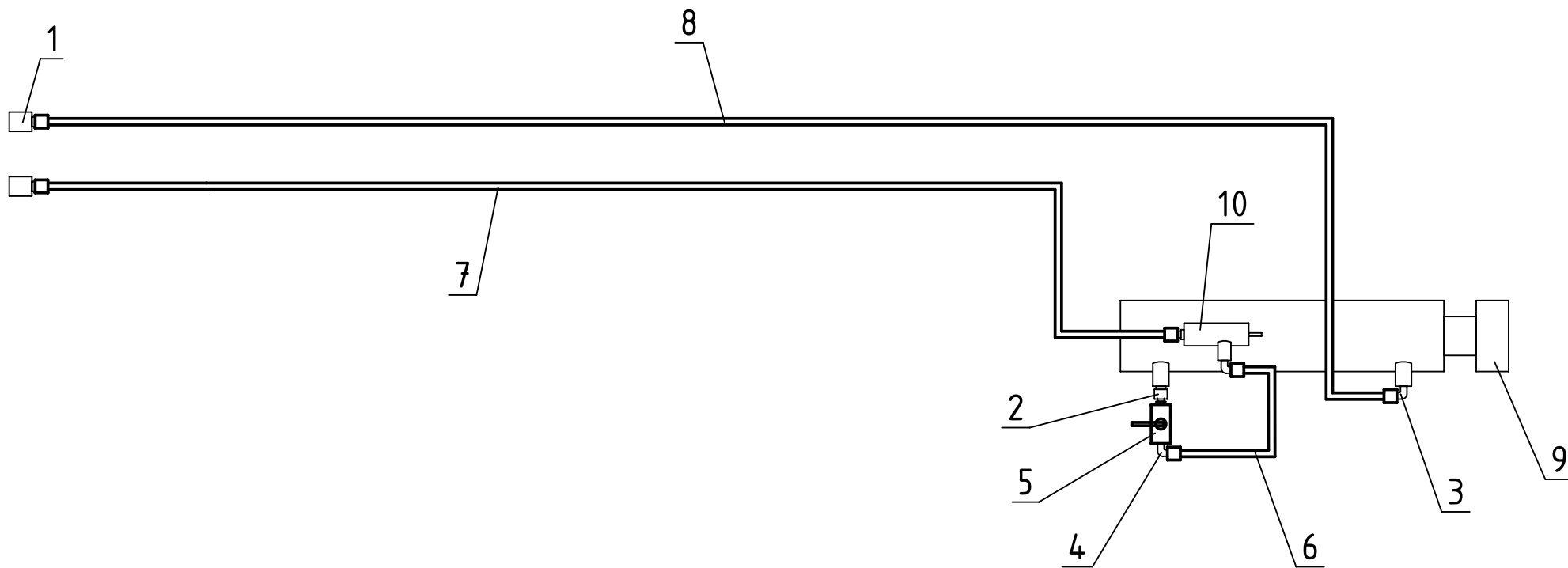

APXE-TL

Rep.	Nom du produit	Beschreibung	Description	Designacion	Наименование	Code
1	Coupleur male 1/2 à clapet/(male 18x150 (12L))	Kuppler/	Coupler/	Cuerpo/	Муфта наружная 1/2 шарик	HYD10710
2	Union M 12L - M 3/8 conique/REPLACE PAR HYD10	Ölanschluss/	Oil connector/	Empalme/	Соединение 4A12 12-17/	HYD10016
3	Coude M 12L - M 3/8 conique/	Ölanschluss/	Oil connector/	Empalme/	Колено наружное коническо	HYD10305
4	Union F 12L - M 3/8 cyl/tournant	Ölanschluss/	Oil connector/	Empalme/	Переходник (с вращающейс	HYD10201
5	Robinet 2 voies F 3/8/	Hahn/	Tap/	Espita/	Кран с 2 выходами 8 FG 3/8	HYD00023
6	Flexible FF TD2C8 EFR12L-EFR12/L lg 300	Schlauch/	Hydraulic hose/	Tuberia/	Шланг FF TD2C8 EFR12L-	FFD00308
7	Flexible FF TD2C8 EFR12L-EFR12/L lg 4700	Schlauch/	Hydraulic hose/	Tuberia/	Шланг FF TD2C8 EFR12L-	FFD04708
8	Flexible FF TD2C8 EFR12L-EFR12/L lg 4900	Schlauch/	Hydraulic hose/	Tuberia/	Шланг FF TD2C8 EFR12L-E	FFD04908
9	Vérin DE: 50x100 C: 200 EF:480/douillé Ø30,5 prise dé	Zylinder/	Cylinder/	Cilindro hidraulico/		VER05004
9	Pochette de joints pour vérin/DE: 50x100 (après 1985)	Dichtungen/	Seal kit/	Juntas/	Комплект прокладок для ги	PJT05001
10	Butée cylindrique complète/sans raccord	Zylinder/	Cylinder/	Cilindro hidraulico/		HYD00028